

# Installation guide ECO2

## Parts of the air-forced heater ECO2

1. Rear part, collar, heating element, electronic part and contacts for supply voltage (230V) and for the thermostat cabling
2. Perforated cover
3. Fixing screw for the perforated cover (2 pcs)
4. Fixing screw for the rear part (to a wall, 4 pcs)

## Installation of the air-forced heater ECO2

1. Drill holes into the wall for wires and fixing screws (4), using the cutout template supplied with the delivery (for the cutout template see Appendix 1).
2. The minimum distance of the supply air unit from the ceiling is 70 mm (see Figure 1.1). The minimum installation height from the floor is 1,8 m. The diffuser must be installed in a place where children can't touch it without supervision.
3. Remove the two fixing screws (3) of the perforated cover (2) and pull the cover away from the rear part (1).
4. Push the collar of the rear part inside the supply air duct and fix the rear part to the wall, using four screws (4), Ø max 5 mm.
5. Connect the supply cable of the supply air unit (MMJ) and the control cable of the thermostat (KLMA) to the terminals of the electronic part of the supply air unit as shown on Figure 2.
6. Check that all the connections are correct. Push the perforated cover back onto the rear part and fix it properly using the fixing screws of the cover.
7. Mark the power switch and temperature drop function switch clearly.

## Connection

1. Connect supply voltage (230V) to terminals N and L of the electronic part of the supply air unit as shown on Figure 2.
2. Connect the grounding to the separate ground terminal in the supply air unit as shown on Figure 2.
3. Connect the supply air unit of the ECO series to the thermostat by means of the KLMA cable as shown on Figure 2.
4. You can activate temperature drop function by connecting terminals Z1 and G0 in the thermostat as shown on figure 5.
5. When two or more forced-air heaters are controlled with one thermostat, the G pole of the power unit in only one supply air unit is connected. The poles G0 and A2 are again connected from all controlled power units. The supply air devices must be connected in the same phase in the distribution box.

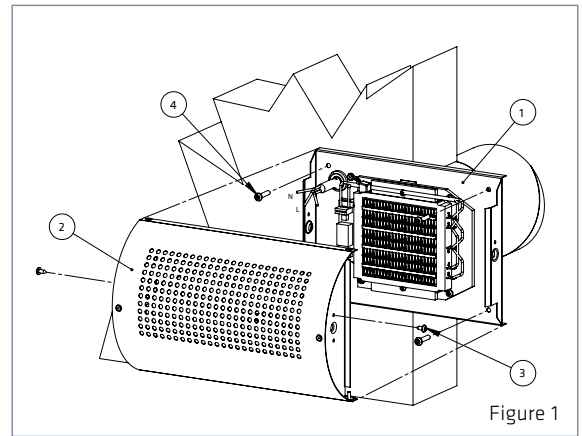

Figure 1

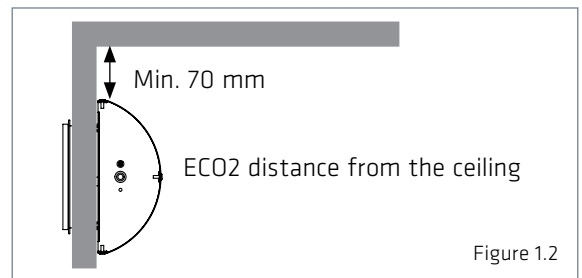

Figure 1.2

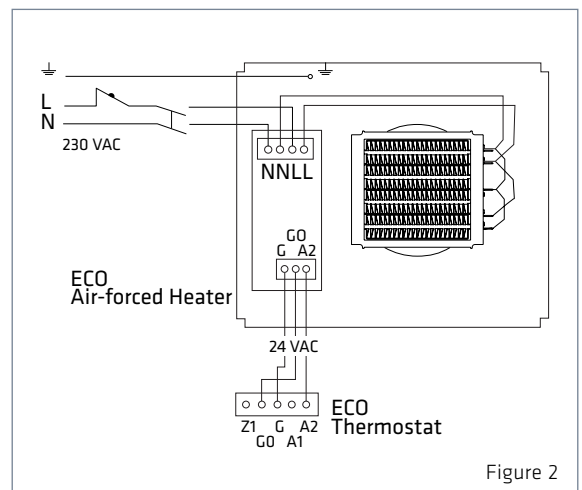

Figure 2

**Note! Connection may be performed only by a person with necessary professional skills.**

**WARNING! 230V voltage inside the unit.**

**U = 230V**  
**I<sub>n</sub> = 2,4 A**  
**I<sub>A</sub> = 3,7 A**

## Cabling modes of the ECO heating system

An all-pole switch must be used on the connection cable. All-pole switch with at least 3mm contact opening shall be used.

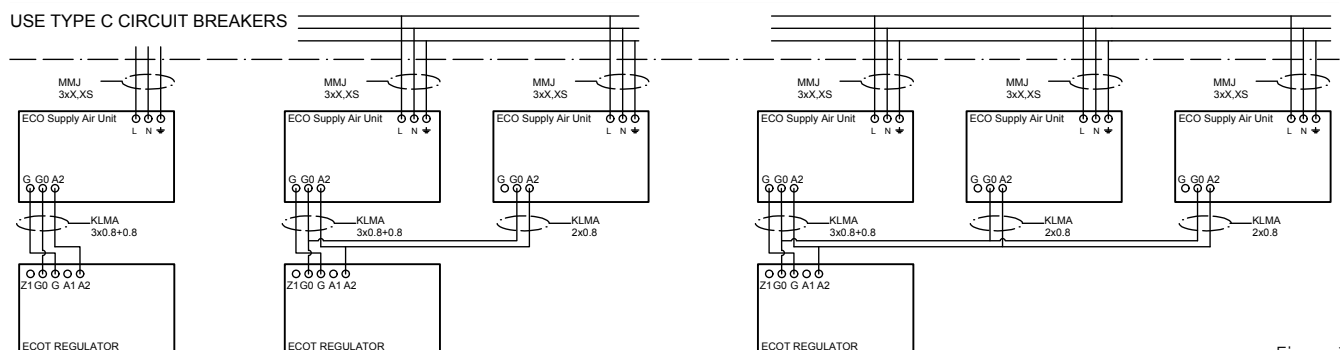

Figure 3

# Installation guide ECOT, thermostat

## Parts of ECO thermostat

1. Rear part
2. Cover
3. Fixing screw (to a wall, 2 pcs)
4. Temperature control knob
5. Terminal block
6. Signal LED
7. Temperature display
8. Control knob for changing the setting value of temperature drop
9. Jumpers S2 and S3

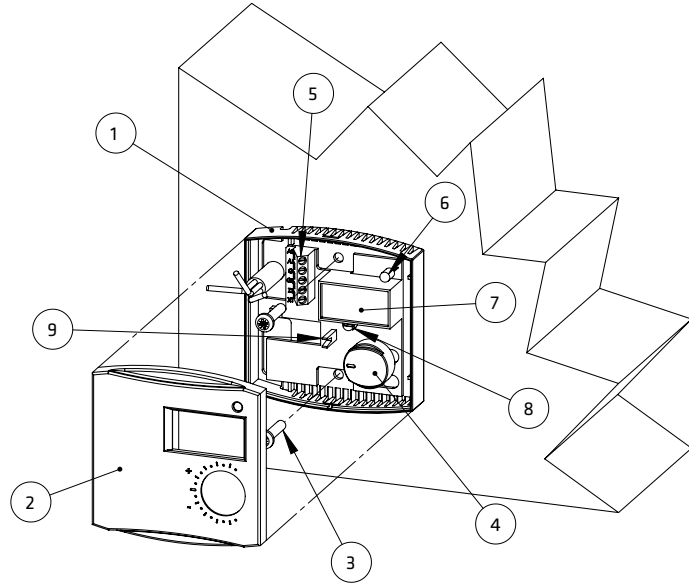

Figure 4

## Installation of the thermostat:

1. Bring the cable intended for the thermostat unit (KLMA) from the supply air unit either to the instrument box (60 mm spacing between holes) or directly to a surface-mounted ECO thermostat.
2. Remove the cover (2) of the thermostat from the rear part (1), using e.g. a small screwdriver (clips at the upper and lower edge of the thermostat).
3. Fix the rear part of the thermostat either to the instrument box or directly on the wall, using screws (3).
4. Connect the cables to the terminal block (5) as shown on Figure 2.
5. If the temperature drop function is taken into use, connect it as shown on Figure 5.
6. After all the connection work, check the connections and reinstall the cover of the thermostat.

## Commissioning

1. Make sure that the connections are made correctly. Turn on the 230V supply voltage coming to the supply air unit. The display (7) will show the room temperature and the LED (6) will light up. The factory setting of the thermostat is 21°C (central point of the setting area) and if the room temperature is lower, the led will turn red and the heating will be switched on, otherwise a green led will be illuminated.
2. When the value of the thermostat is changed ( $\pm 3^{\circ}\text{C}$  from the value of the central point) with the control knob (4), you can see the new setting value on the display (7).
3. Changing the central point of the setting area to e.g. 24°C. Open the cover (2) of the thermostat and turn the temperature control knob (4) up (extreme position). Remove jumper S3 and install it back to its position. The new central point of the setting area will now be 24°C.
4. The factory set accuracy of temperature adjustment is  $\pm 0.5^{\circ}\text{C}$ . If you need to change the accuracy to  $\pm 1^{\circ}\text{C}$ , remove jumper S2.
5. Temperature drop from the setting value of  $3^{\circ}\text{C} \dots 10^{\circ}\text{C}$  is adjusted from the knob (8). The value of temperature drop is visible on the display (7).
6. After you have made all the necessary changes, reinstall the cover (2) and the system is ready for use.

### Temperature drop alternatives of ECO thermostat

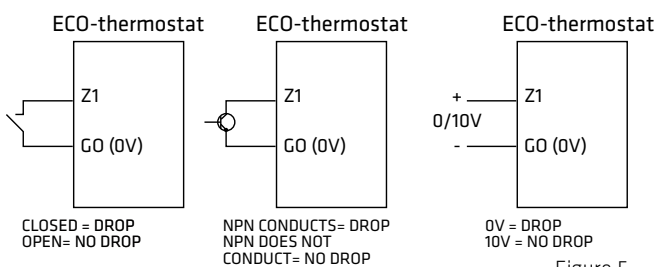

Figure 5

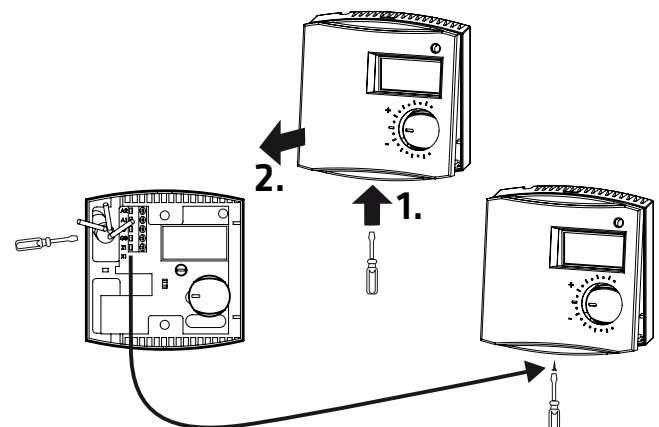
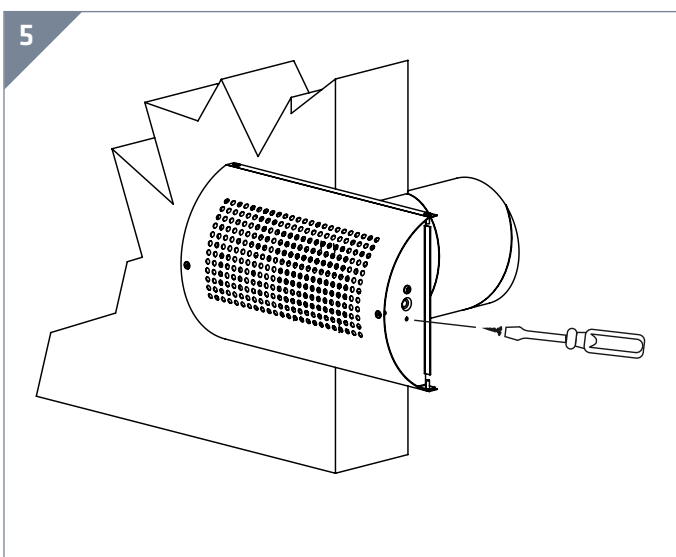
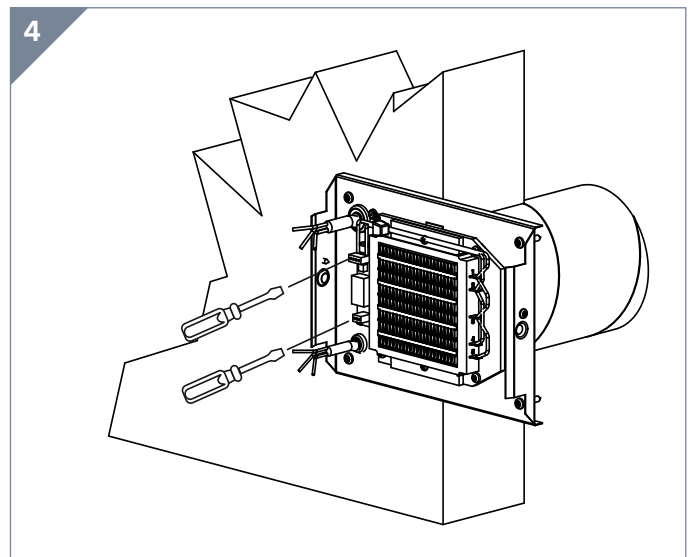
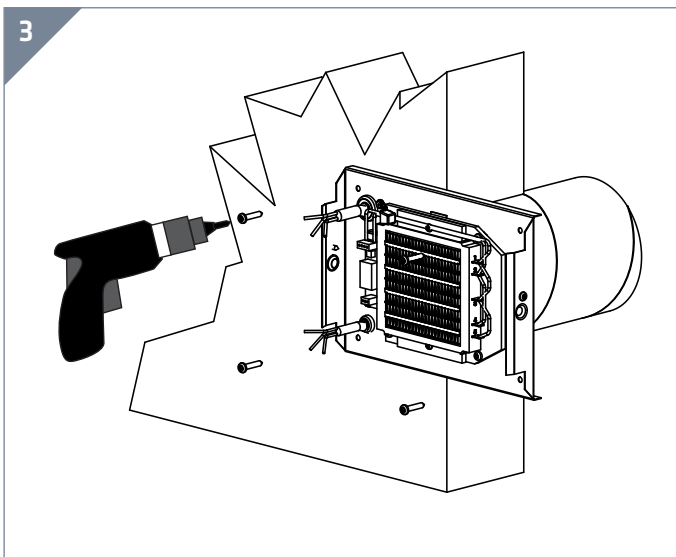
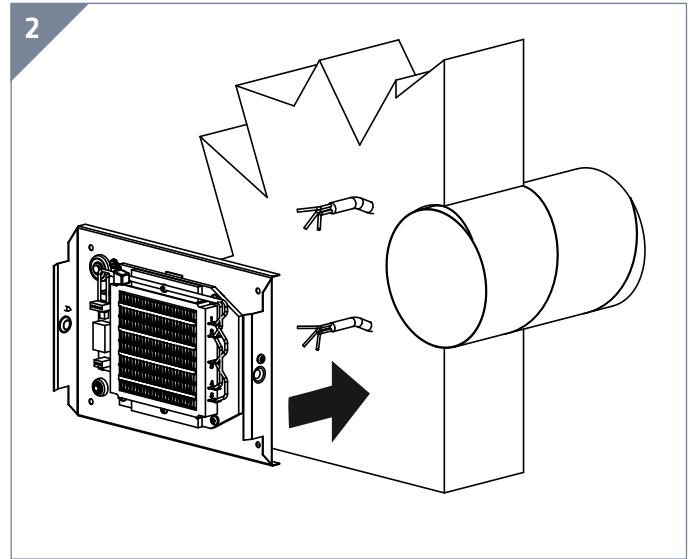
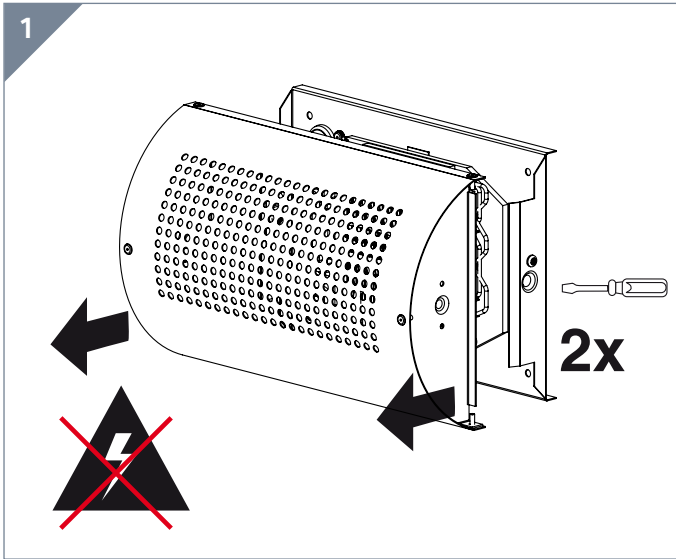

Figure 6

# Installation instructions ECO2

Note! Connection work may be performed only by a person with necessary professional skills.



## Service instruction ECO2

Note! Connection work may be performed only by a person with necessary professional skills.  
 Warning! 230V voltage inside. Turn off the supply voltage before maintenance.  
 Note! Check also the condition of the supply air filter of the air handling unit.

